

**CITY OF AMITY**  
**DOWNTOWN DEVELOPMENT**  
**STANDARDS**  
**1<sup>ST</sup> ADDITION**



## **DOWNTOWN DEVELOPMENT**

### **INTRODUCTION**

The City of Amity’s Capital Improvement Program (CIP) identified a project for the “Downtown Revitalization”. The purpose of these standards is to further define the improvements to fulfill these project goals. This document is intended to accompany and further define the City of Amity Public Infrastructure Design Standards for the Downtown Development area as defined herein. These standards and details supersede those contained in the City of Amity Public Infrastructure Design Standards if conflicts occur.

### **DOWNTOWN DEVELOPMENT AREA**

The downtown development area is defined as the following: Trade Street from the north city limits to the south city limits; 5<sup>th</sup> Street from the west city limits to Trade Street; Nursery Avenue from Trade Street to the east city limits; The area west of Trade Street bounded by 1<sup>st</sup> Street, Stanley Street and 6<sup>th</sup> Street, inclusive; And the area east of Trade Street bounded by 3<sup>rd</sup> Street, Getchell Avenue and Nursery Avenue.

## **STANDARDS**

### **GENERAL**

All improvements will be designed and constructed in accordance with the City of Amity Public Infrastructure Design Standards unless otherwise specified herein. All improvements will be submitted and approved by the City Engineer.

### **STREETS**

The City Street Standards within the Downtown Development Area will be as specified herein. Streets will include bulb-outs at the intersections where parking is provided. Turning movements will be analyzed to accommodate both the design vehicle and the maximum vehicle identified by the City Engineer. Grades will take into account all existing building access points on both sides of affected streets to insure future constructability.

## **SIDEWALKS**

Sidewalks will be constructed to a minimum width of 6 feet unless otherwise indicated. Sidewalks may be further divided into three zones (Sidewalk, Building Zone and Furnishing Zone).

Sidewalks within the downtown core area will be constructed to a minimum width of 10 feet in accordance with ODOT requirements, but will be constructed to the design specifications contained herein including scoring pattern, street tree placement, sign placement, light placement, etc.

Sidewalks within the Transition areas will be constructed to a minimum width of 8 feet. The width of the curb may be included in these measurements.

Within the downtown core the addition of decorative streetlights and street trees will be included with all new development or redevelopment. These features will include an underground electrical system with meter base installations as required and an underground irrigation system for the street trees and streetlights. The irrigation system will be designed to isolate the street trees from the hanging baskets on the streetlights. In addition the streetlight hanging baskets will be supplied by a drip system. The irrigation system will be automatic and include controllers spaced to minimize the number required and the location of. In addition, provisions will be made for the placement of flags, benches, trashcans, etc.

## **UTILITIES**

All city utilities will be upgraded to the current master plan or capital improvement plan requirements at the time of development or redevelopment. All other utilities will be provided underground.; Existing above ground utilities will be moved or placed underground at the time of new development or redevelopment. Above ground features (i.e.: transformers, cabinets, pedestals, etc.) will not be permitted within the public right-of-way without the approval of the City Engineer.

## **EQUIPMENT LIST**

Street Trees:

Tree Grates: 36"x72" KIVA by Urban Accessories

Street Lights: Amity by Visco

Pull Boxes:

Meter Cabinet:

Benches:

Trashcans:

Irrigation Equipment:

Controller: Rainbird ESP-MC-SS (8 station)

Valves: Standard-Rainbird 100-PEB or Drip-Rainbird X CZ-100

Gate Valves: NIBCO T-113

Quick Couplers: Rainbird 44-RC

Backflow Preventor: Watts 1.5" No. 007

Valve boxes: Armorcast

## **DRAWINGS**

### **INDEX**

Detail 1A ; Amity City Street Standard (B-1 Local Collector)

Detail 1B: Amity City Street Standard (C Commercial Collector)

Detail 1C: Amity City Street Standard (D Arterial or Industrial)

Detail 2: Typical Bulb-Out

Detail 3: Downtown Sidewalk Details with on street Parking

Detail 4: Downtown Sidewalk Details without on street Parking

Detail 5: Streetlights and Street Tree Layout Details.

Detail 6: Streetlight Foundation

Detail 7: Miscellaneous Details

Detail 8: "Amity" streetlight by Visco

Detail 9: Downtown Sidewalk Details without Parking (Restricted Right-of-Way Width)  
(Allowed only upon approval from the City Engineer)

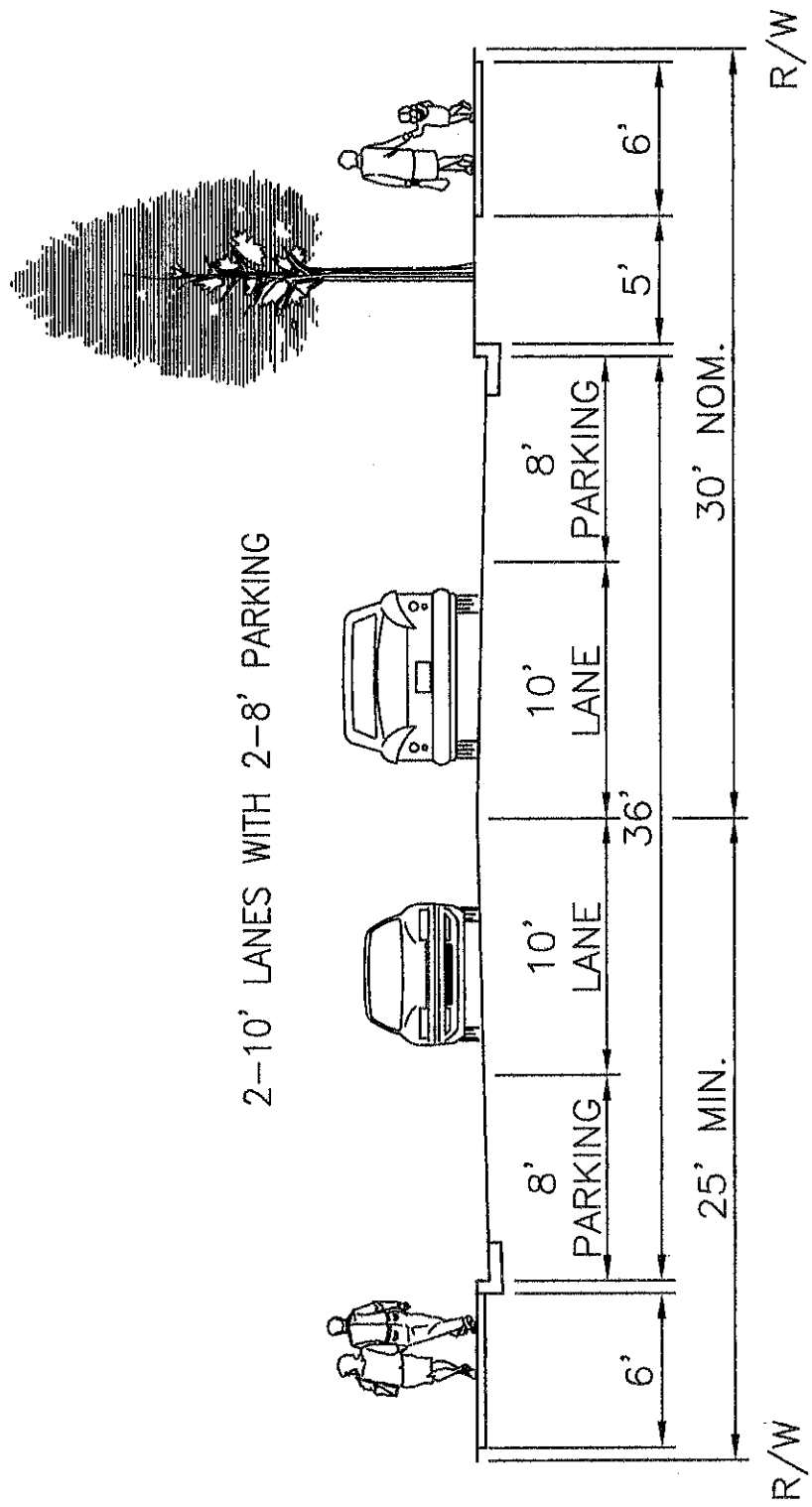

# B-1 - LOCAL COLLECTOR

AMITY CITY STREET STANDARD

SCALE:  
N.T.S.



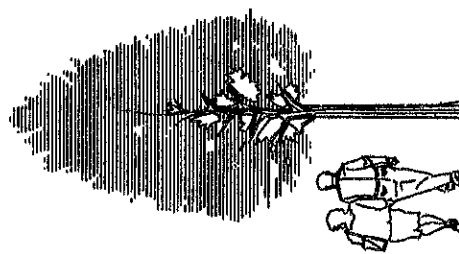

2-14' SHARED LANES WITH 2-8' PARKING

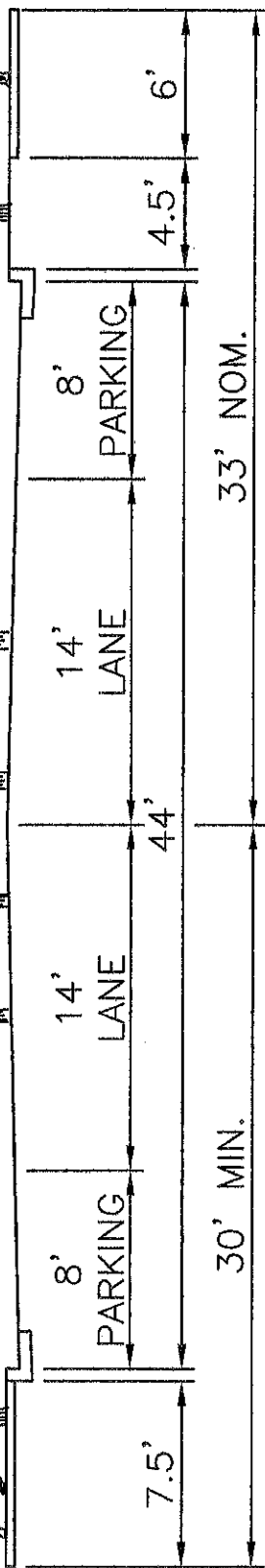
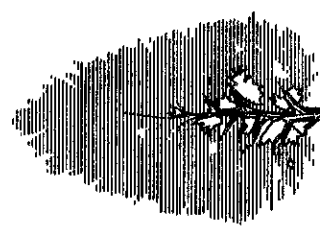

R/W

R/W

# C - COMMERCIAL COLLECTOR

AMITY CITY STREET STANDARD

SCALE:  
N.T.S.



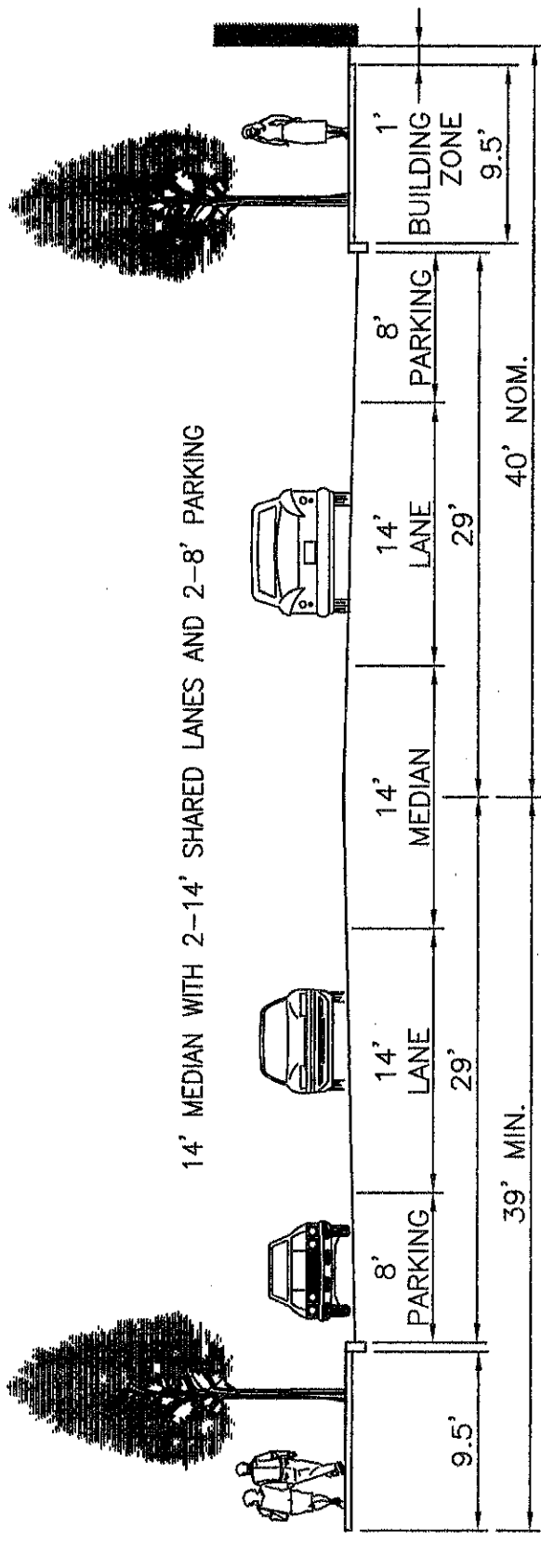

D- ARTERIAL OR INDUSTRIAL (TRADE STREET)

AMITY CITY STREET STANDARD

SCALE:  
N.T.S.

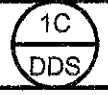



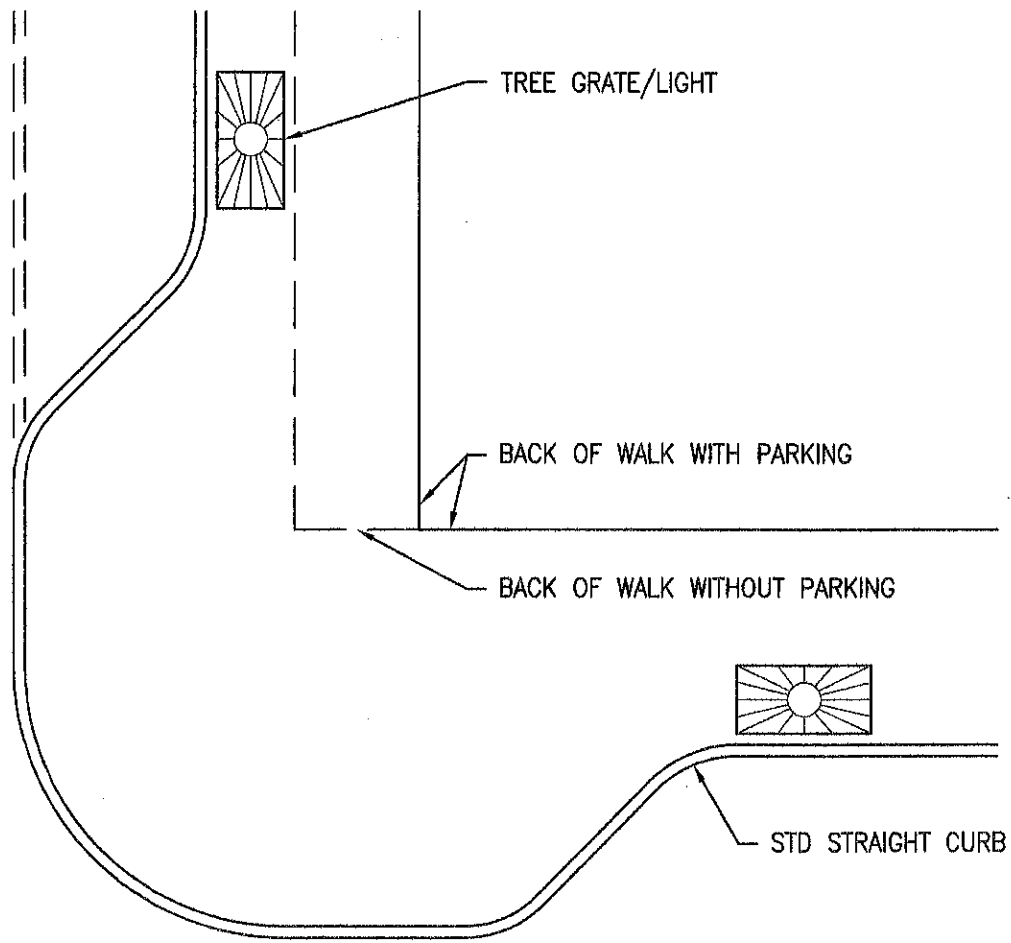

STANDARD SIDEWALK CONFIGURATION

AMITY TYPICAL BULB-OUT

SCALE:  
N.T.S.

2  
DDS

BACK OF SIDEWALK

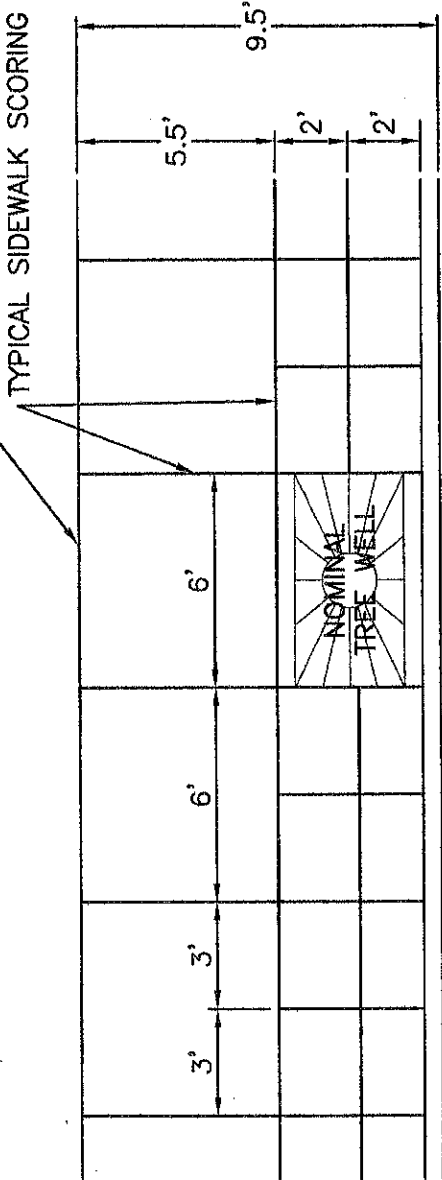

NOTES:

1. METAL TREE GRATE AND FRAME MUST BE ASSEMBLED PRIOR TO PLACING CONCRETE SIDEWALK.
2. ALL SCORING DIMENSIONS ARE NOMINAL. SCORING SHALL BE ADJUSTED TO MATCH OUTSIDE OF TREEWELL FRAME.

STD STRAIGHT CURB

### TYPICAL SIDEWALK SCORING DETAIL FOR 10 FOOT SIDEWALK

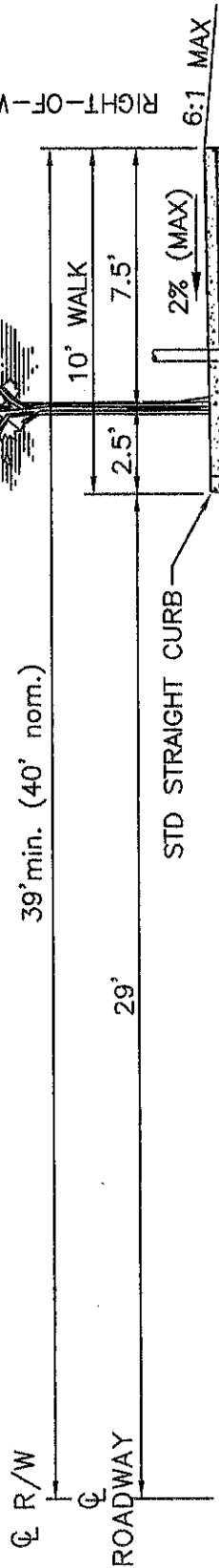
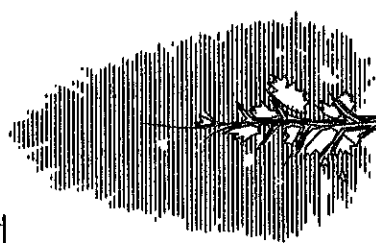

31.5' TREE GRATE OR LIGHT POST  
33.25' SIGN POST

4" CONC. SIDEWALK  
(6" CONC. DRIVEWAYS)

### TYPICAL SECTION WITH PARKING

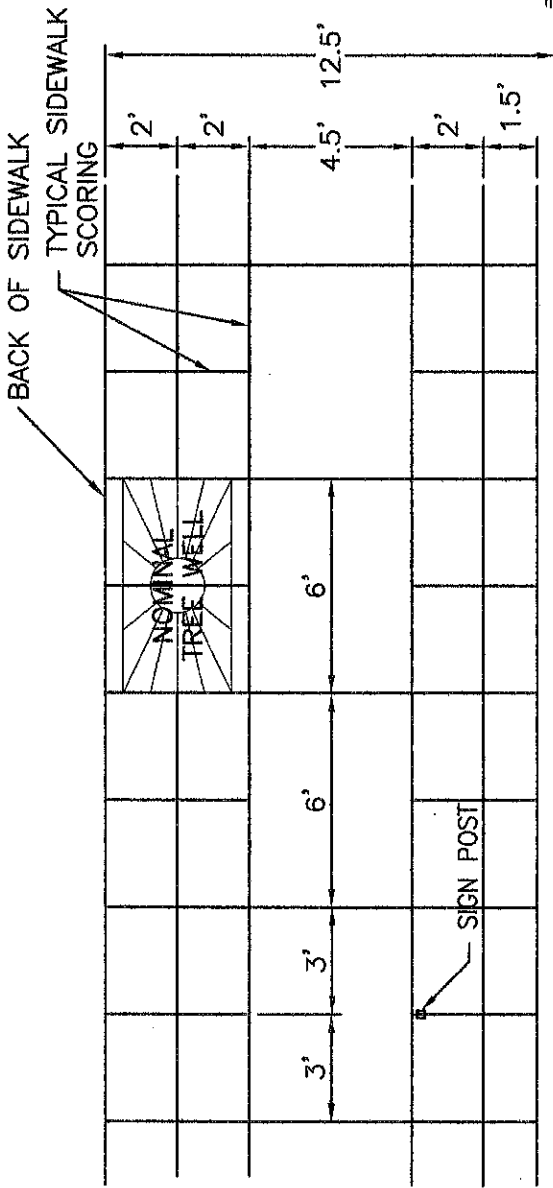

**NOTES:**

1. METAL TREE GRATE AND FRAME MUST BE ASSEMBLED PRIOR TO PLACING CONCRETE SIDEWALK.
2. ALL SCORING DIMENSIONS ARE NOMINAL. SCORING SHALL BE ADJUSTED TO MATCH OUTSIDE OF TREEWELL FRAME.

**TYPICAL SIDEWALK SCORING DETAIL FOR 10 FOOT SIDEWALK**

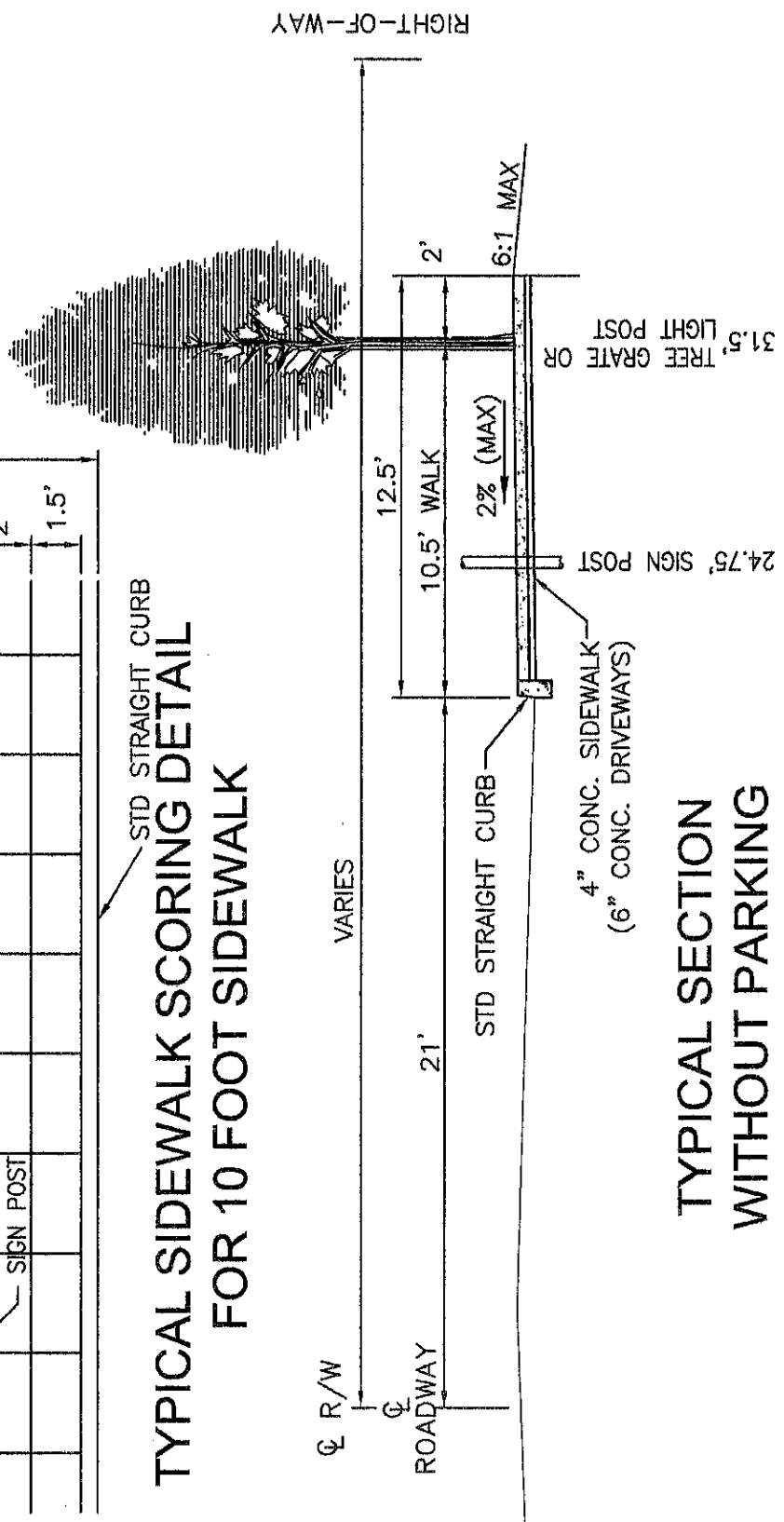

**TYPICAL SECTION WITHOUT PARKING**

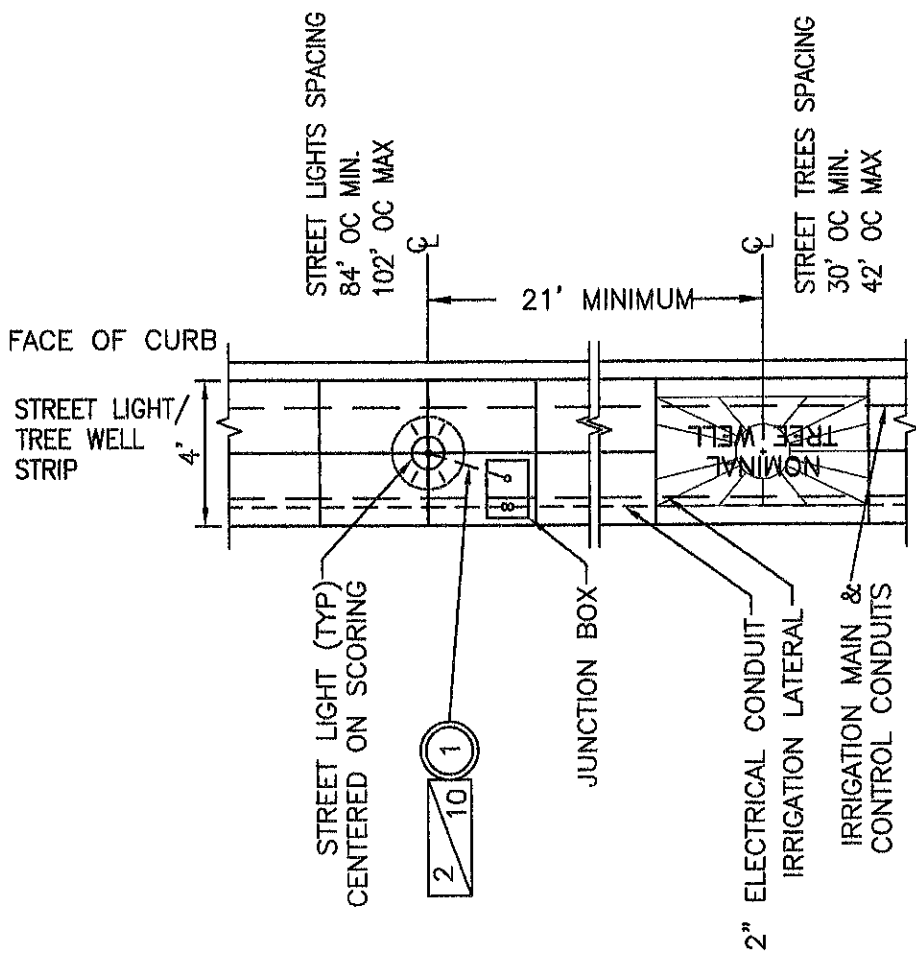

**NOTES:**

1. CONTRACTOR TO INSTALL 2-1/C #10 CONDUCTORS FROM LUMINAIRE TO JUNCTION BOX IN TREE WELL/STREET LIGHT STRIP.
2. A WATER PROOF FUSEHOLDER IS REQUIRED AT EACH LUMINAIRE.
3. STREET LIGHT SPACING SHALL BE ADJUSTED TO PROVIDE A MINIMUM OF THREE LIGHTS PER BLOCK, ONE ON EACH CORNER AND ONE MID BLOCK. SPACING IS NOT CONTINUOUS THROUGH INTERSECTION OR MAJOR COMMERCIAL DRIVEWAYS. SPACING WILL ALSO BE ADJUSTED TO FACILITATE PEDESTRIAN CROSSINGS.

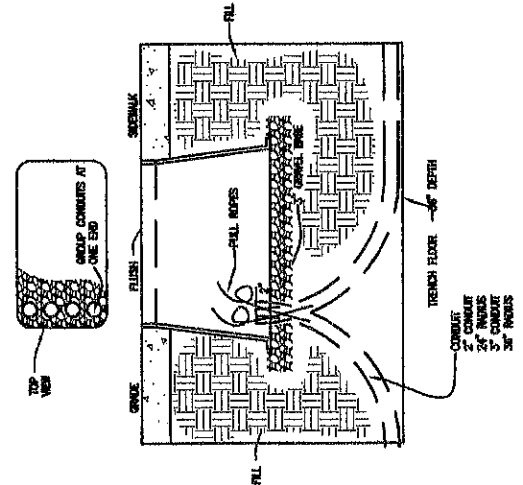
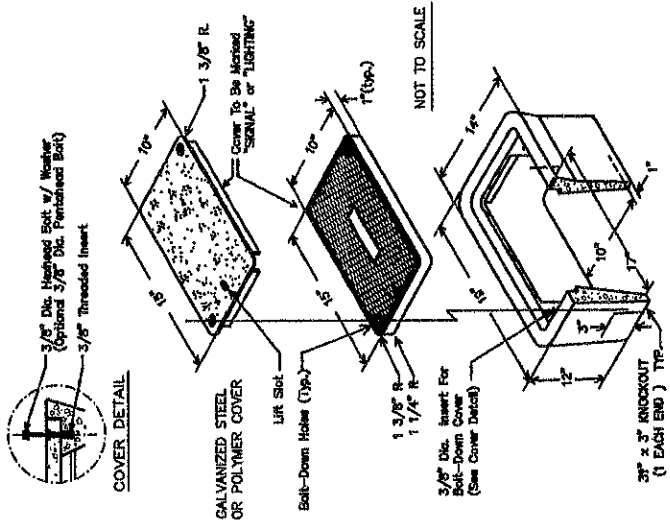

**STREET LIGHT & TREE LAYOUT DETAILS**

SCALE:  
N.T.S.

**GROUND ROD :**

- G1.- MINIMUM 3" EXPOSURE AT TOP OF FOUNDATION, WITHIN BOLT CIRCLE.
- G2.- GROUND ROD SHALL BE MINIMUM 5/8" DIA. X 8 FT LONG, COPPER CLAD.

**ANCHOR BOLTS :**

- A1.- (4) ASTM A449 ANCHOR BOLTS PER SPECIFICATIONS
- A2.- BOLT CIRCLE DIAMETER TO MATCH POLE BASEPLATE
- A3.- ANCHOR BOLTS SHALL HAVE HEADS, OR NUTS WITH THE THREADS STAKED AT TWO PLACES BELOW THE NUT, EMBEDDED IN FOUNDATION.
- A4.- ANCHOR BOLTS SHALL BE 39" LONG WITH 33" EMBEDMENT IN CONCRETE.
- A5.- BOLT PROJECTION AS RECOMMENDED BY THE MANUFACTURER.

NOT TO SCALE

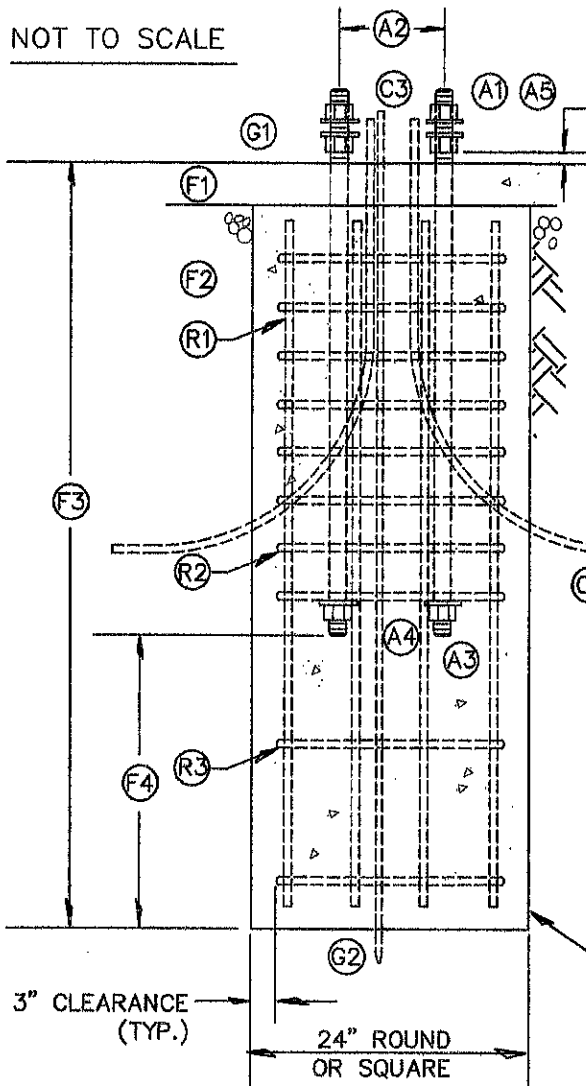

**CONDUIT :**

- C1.- CONDUIT SHALL BE RGS IN CONCRETE WITH 6" MINIMUM STUB-OUT.
- C2.- SERVICE AND FEED CONDUITS SHALL BE RGS OR PVC, AS REQUIRED.
- C3.- STUB UP TO WITHIN 4" FROM HAND HOLE.

36" MINIMUM BURIAL  
42" MAXIMUM BURIAL

**REINFORCEMENT :**

- R1.- VERTICAL REBAR SHALL BE 7-#6 EQUALLY SPACED INSIDE OF HOOPS.
- R2.- HOOPS SHALL BE #4 X 18" O.D., SPACED 4" O/C FROM TOP OF FOUNDATION TO END OF ANCHOR BOLTS.
- R3.- HOOPS SHALL BE #4 X 18" O.D., SPACED 12" MIN. FROM THE ANCHOR BOLTS TO BOTTOM OF FOUNDATION.

POUR FOOTING AGAINST UNDISTURBED MATERIAL

**NOTE :**

90 DEGREE BENDS IN ANCHOR BOLTS WILL NOT BE PERMITTED.

**FOUNDATION :**

- F1.- THE TOP 3 1/2" OF ROUND FOUNDATIONS SHALL BE INTEGRATED INTO SIDEWALK OR Poured AS A SQUARE PAD, LARGE ENOUGH TO FULLY SUPPORT THE POLE BASE PLATE AND NUT COVERS.
- F2.- THE FOUNDATION SHALL CURE A MINIMUM OF FOURTEEN (14) DAYS PRIOR TO POLE INSTALLATION OR TORQUING OF THE ANCHOR BOLTS.
- F3.- FOUNDATION DEPTH (PD) :
 

POST-TOP POLES	54" DEEP	
30 FOOT POLES	72" DEEP (AVER. SOIL)	90" DEEP (POOR SOIL)
35 FOOT POLES	84" DEEP (AVER. SOIL)	90" DEEP (POOR SOIL)
- F4.- THERE SHALL BE A MINIMUM OF 17" FOUNDATION BELOW THE ANCHOR BOLT HEADS.

**STREET LIGHT FOUNDATION**

SCALE:  
N.T.S.



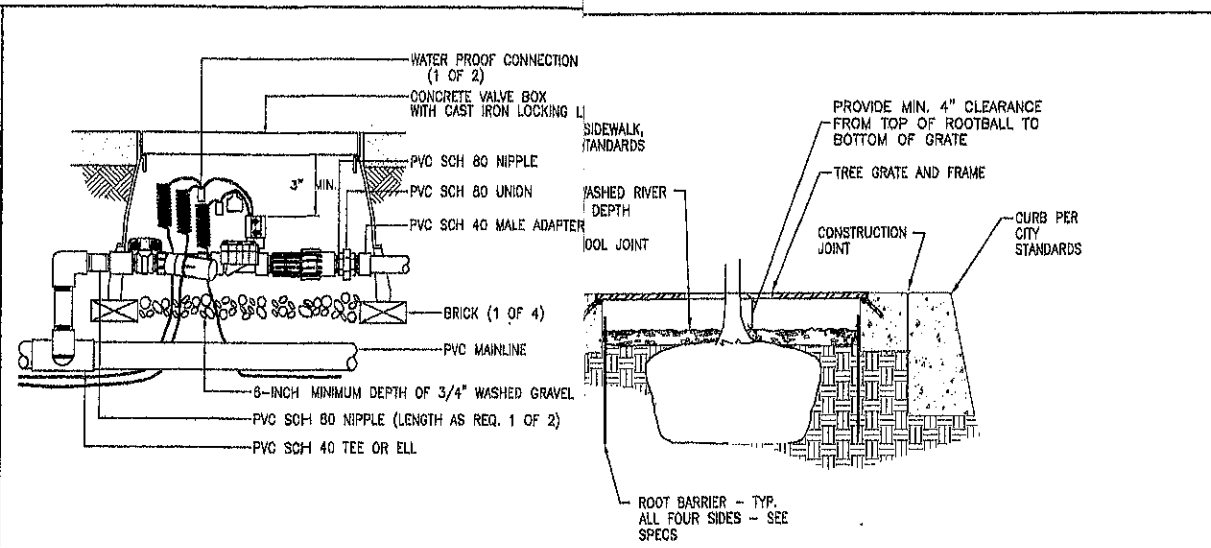

**DRIP IRRIGATION CONTROL VALVE** SCALE: N.T.S. **INSTALLATION** SCALE: 4/DDS N.T.S.

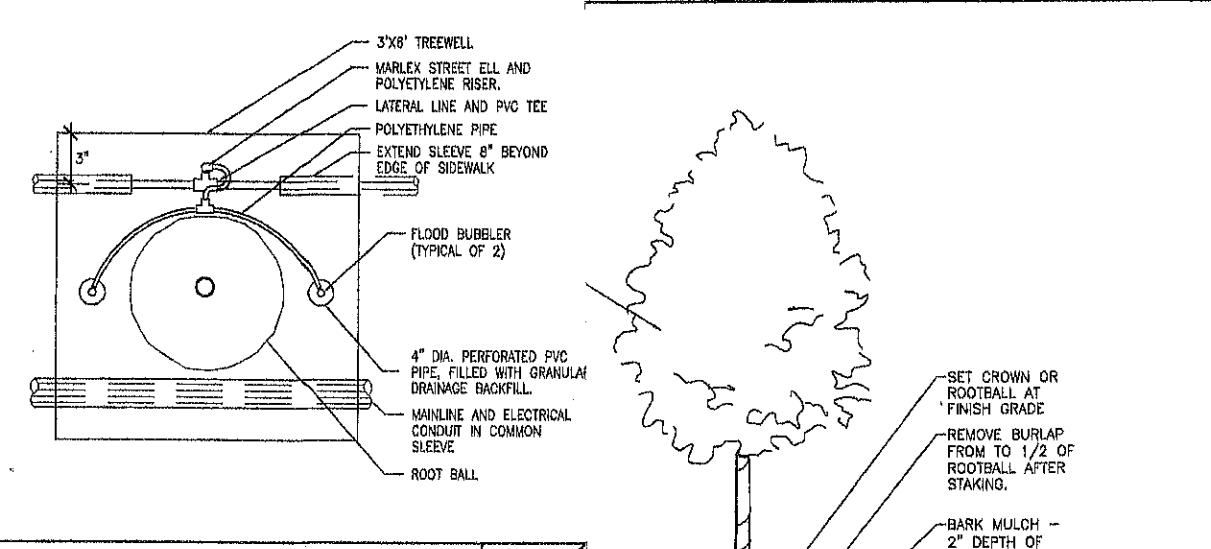

**TREE BUBBLER** SCALE: N.T.S.

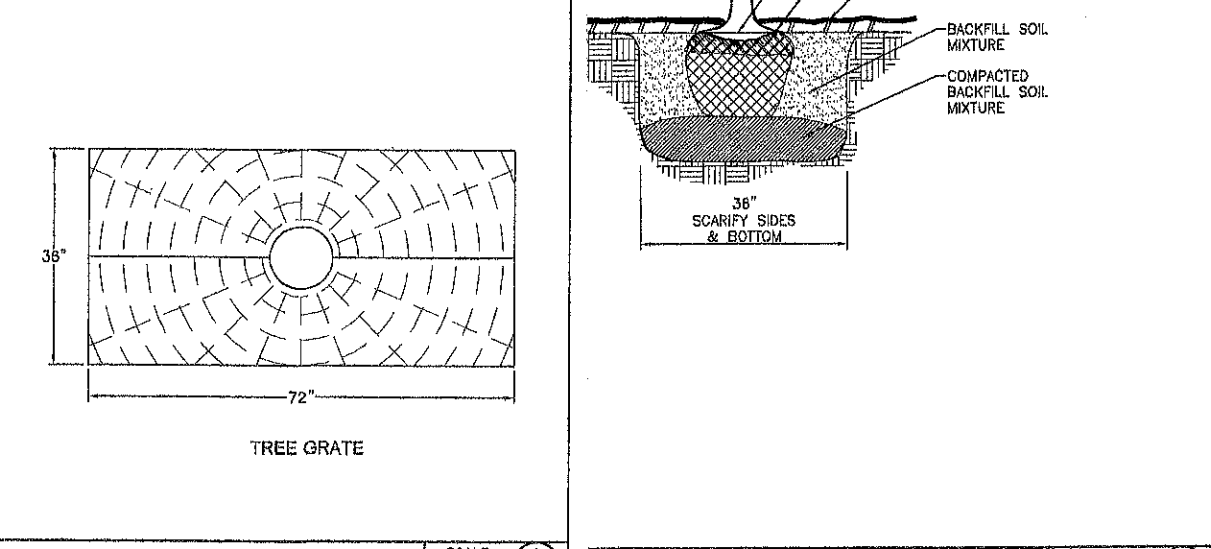

**TREE GRATE DETAIL** SCALE: 8/DDS N.T.S. **INSTALLATION** SCALE: 11/DDS N.T.S.

**PAINT SPECIFICATION**  
 ALL CAST IRON AND STEEL LIGHT POLE PARTS ARE TO BE  
 FACTORY FINISH PAINTED TO A "COLOR TO BE SPECIFIED".

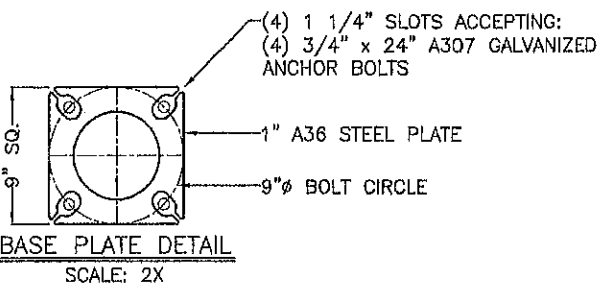
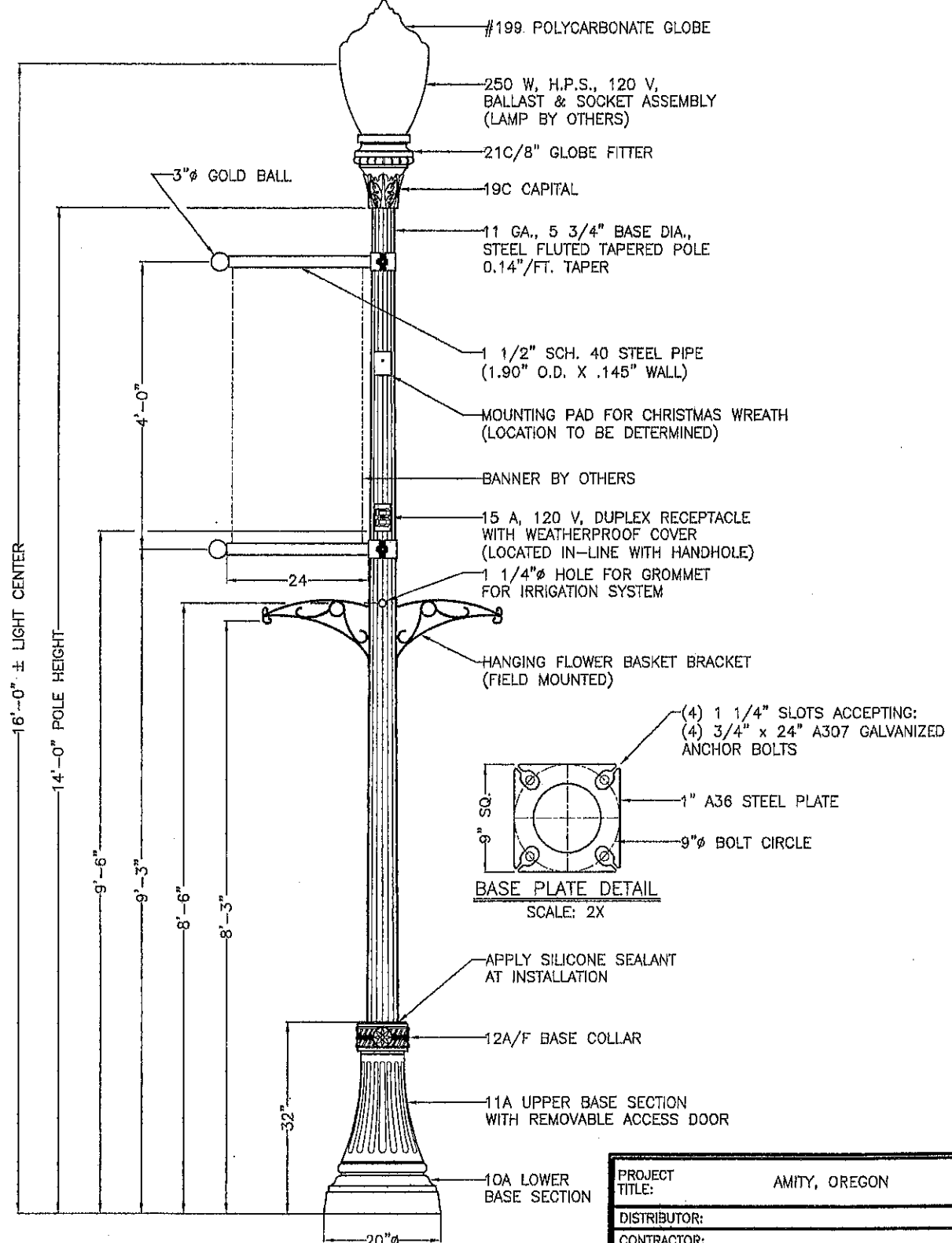

VI-A-1-F/14'  
 ITEM #1

PROJECT TITLE:	AMITY, OREGON	
DISTRIBUTOR:		
CONTRACTOR:		
REPRESENTATIVE:		
	SPECIFIED BY:	
	SCALE: 1"=1'	DATE: 10/20/09
	JOB NO.:	CAD FILE: AMITY
<small>25579 ANDREY LANE EUGENE, OREGON 97402 PHONE (541) 885-7741 FAX (541) 481-0951</small>		

# AMITY DOWNTOWN SIDEWALK DETAILS

## NOTES:

1. THIS DESIGN IS ALLOWED ONLY UPON APPROVAL BY THE CITY ENGINEER.
2. METAL TREE GRATE AND FRAME MUST BE ASSEMBLED PRIOR TO PLACING CONCRETE SIDEWALK.
3. ALL SCORING DIMENSIONS ARE NOMINAL. SCORING SHALL BE ADJUSTED TO MATCH OUTSIDE OF TREEWELL FRAME.

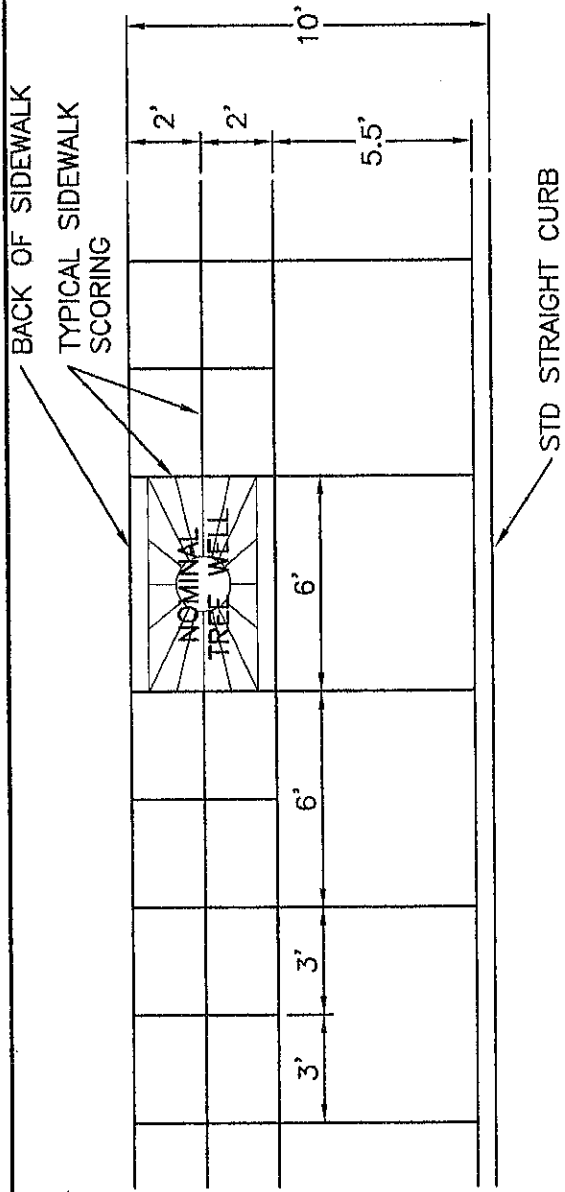

## TYPICAL SIDEWALK SCORING DETAIL FOR 10 FOOT SIDEWALK

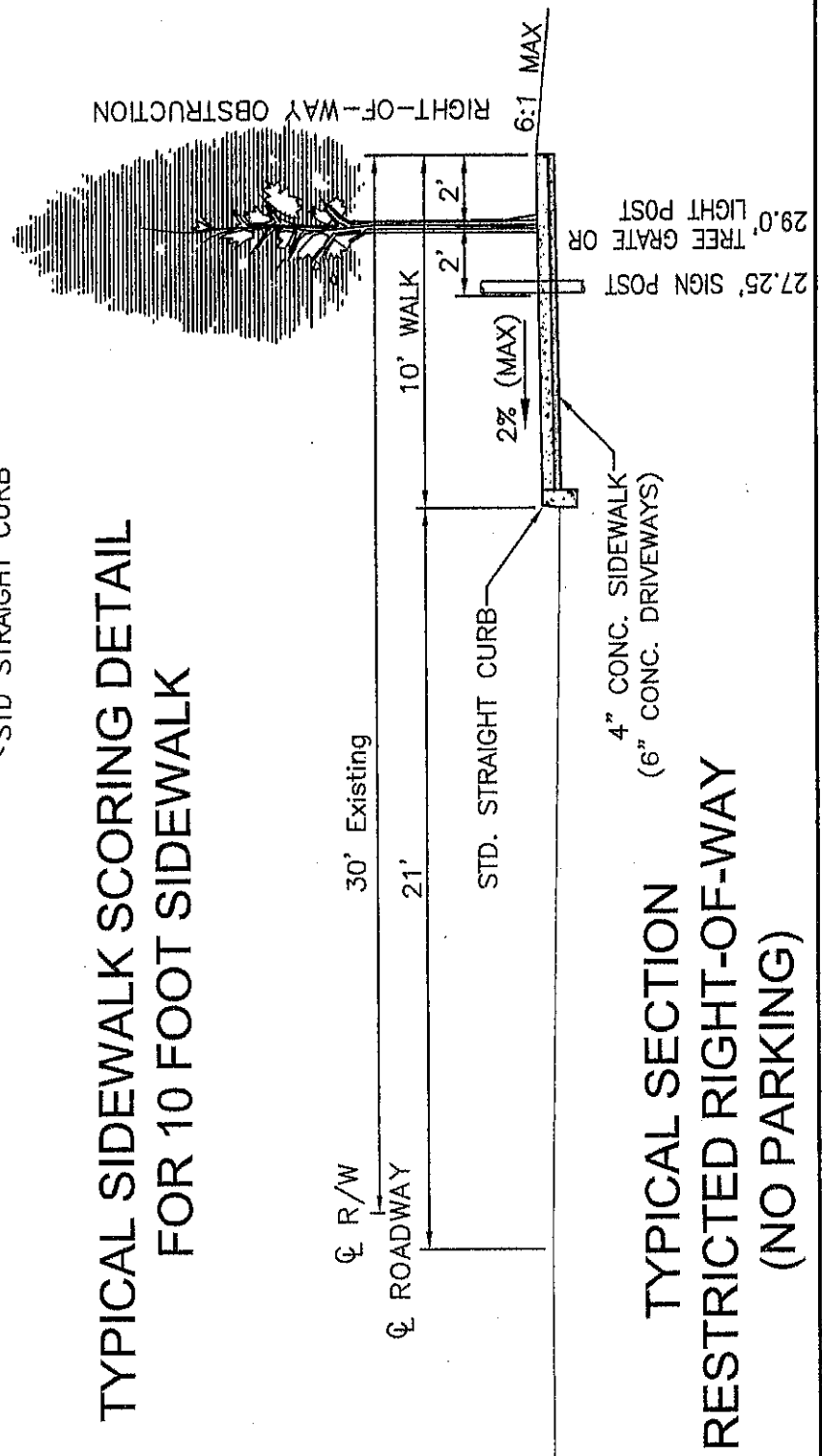

## TYPICAL SECTION RESTRICTED RIGHT-OF-WAY (NO PARKING)

SCALE: N.T.S. 9  
DDS